

# BECKENHAM MAJOR IMPROVEMENT PROJECT

The following plans are the construction drawings for the proposed paving and highway improvements.

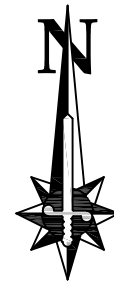



Junction Railway Station

SOUTHERND ROAD

RECTORY ROAD

O'Neill's

Shoe Repairs

ALBEMARLE ROAD

Thai Restaurant

HIGH STREET

BUS STOP

BUS STOP

Notes:

- No information to be scaled from this drawing.
- All road markings refer to the "Traffic Signs Regulations and General Directions 2016". Refer to drawing number BHS/RM/101.
- This drawing is to be read in conjunction with all relevant drawings.
- All levels and co-ordinates in Ordnance Survey Grid.
- This drawing may not be used, modified, reproduced or relied upon by third parties, except as agreed or as required by law. Topocrew accepts no responsibility, and denies any liability whatsoever, to any party that uses or relies on this drawing without express written consent. Do not scale this document.
- Paving orientation is only indicative. For exact paving orientation refer to East's drawing 102-BPR-SK-016-Proposed paving orientation.

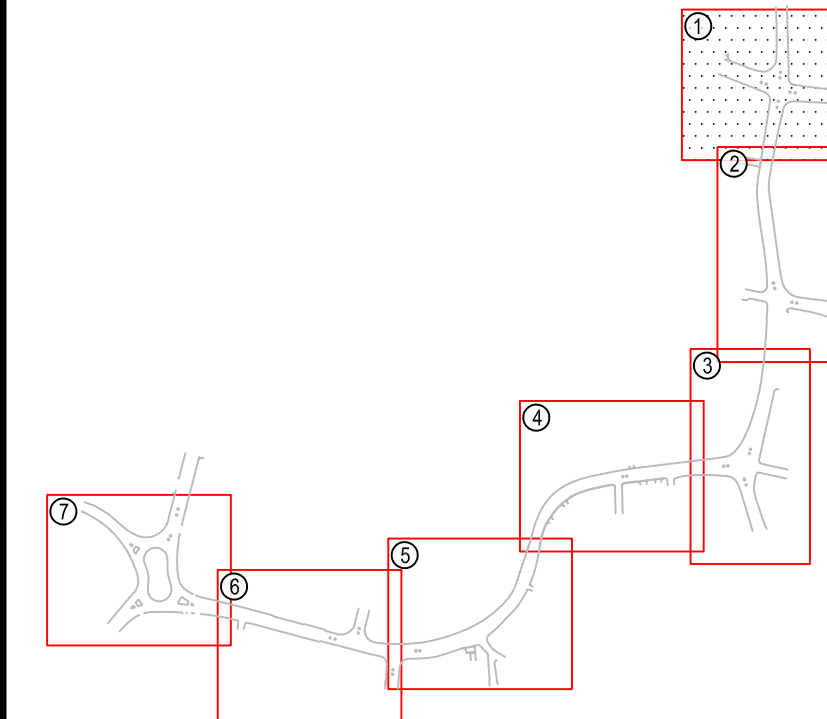

Rev No.	Date	Description	By
G	8 Dec	Various changes	GK
F	23 Nov	Various changes	GK
D	17 Oct	Various changes after second safety audit	GK
C	14 Sep	Various changes after safety audit	GK
B	27 June	First Issue	GK
A	25 May	Various revisions at a result of changes to the scheme	SR

TITLE:  
**Beckenham High Street**  
**General Arrangement**  
**GA 1 Albemarle Road Junction -**

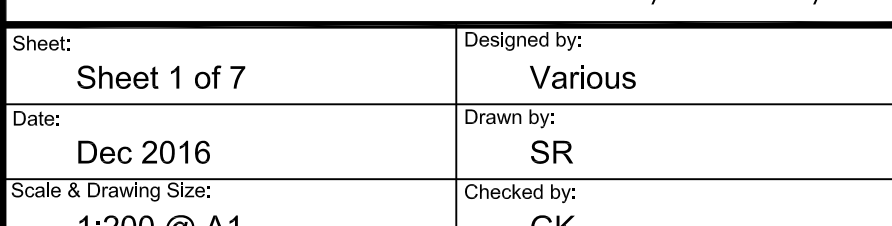

Sheet:	Sheet 1 of 7	Designed by:	Various
Date:	Dec 2016	Drawn by:	SR
Scale & Drawing Size:	1:200 @ A1	Checked by:	GK
Drawing No:	BHS/700/GA	Revision:	G

**KEY**

	CCTV Column (existing retained)		Granite dropper kerb
	CCTV Column (proposed)		Guard railing
	Post box		Red tactile Paving
	'Bell' bollard		Buff Tactile Paving
	Belisha beacon		Buff Cordrouy Paving
	Cycle stand		Milestone
	Lamp column (existing retained)		Bin
	Lamp column (proposed)		Bench
	Wall mounted lantern		Timber seating
	Sign / sign & post (ex. retained)		Electricity point
	Sign / sign & post (proposed)		Planter
	Water point		Steel screen structure
	Traffic signal		Granite seating
	Traffic signal controller		Brick retaining wall
	Cycle repair stand		Granite kerb
	Piano (Art installation)		Proposed tree
	Bus stop flag/time tables		Existing tree
	Bus shelter		Stainless steel rail
	AluExcel rail		
	Slot drain		
	Boundary studs		
	Finger post sign (Wayfinding)		
	Legible London Totem sign		
	Pay and display ticket machine		
	Possible smoke outlet / skylight. Material type & extent to be decided by engineer on site.		
	300x450x60mm granite paving		
	240x160mm Keyblok paving		
	Gravel bound surface		
	200x100x100mm cropped Granite Setts		
	Clay brick paving (spec to be confirmed)		
	Landscaping area		

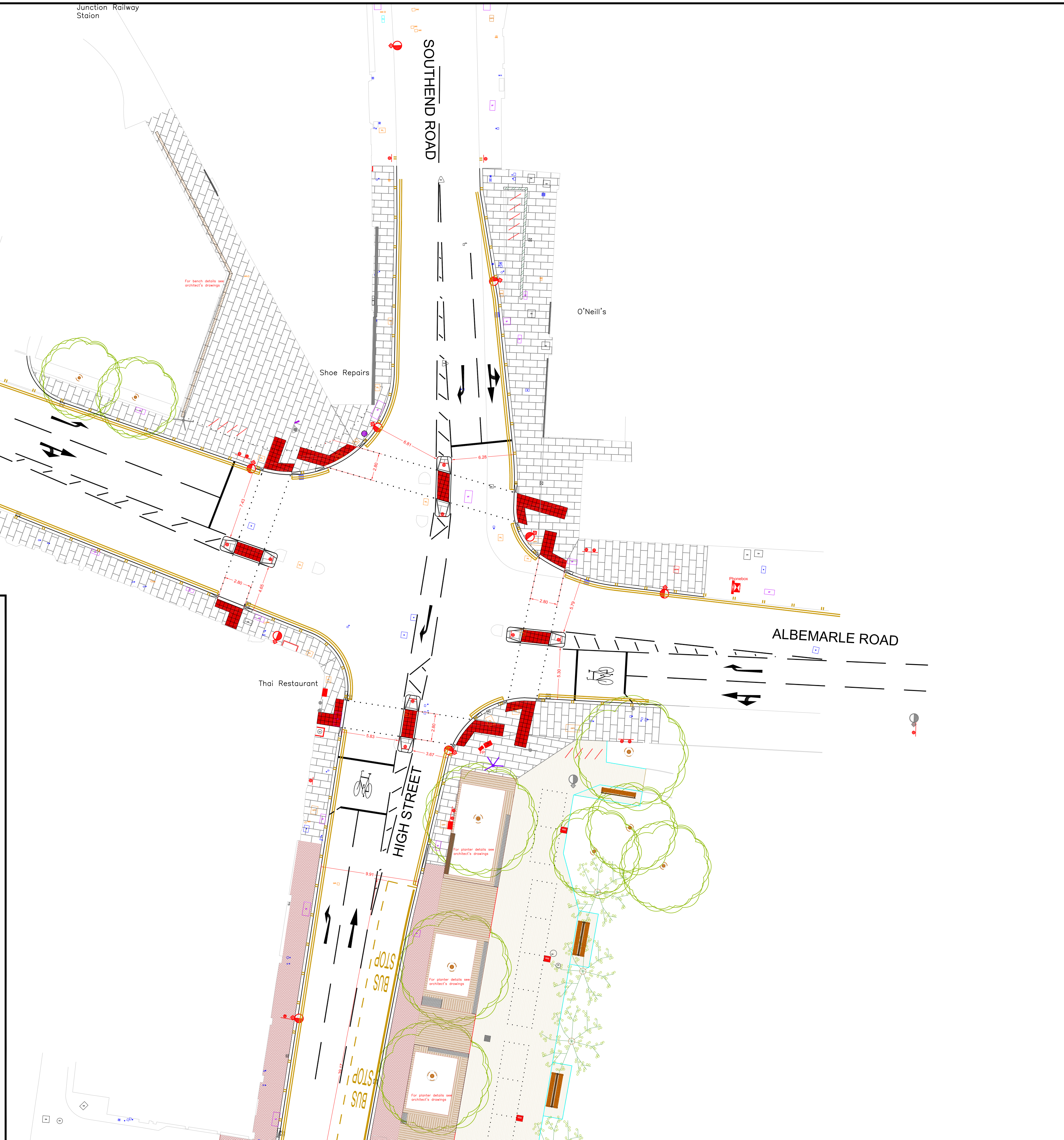



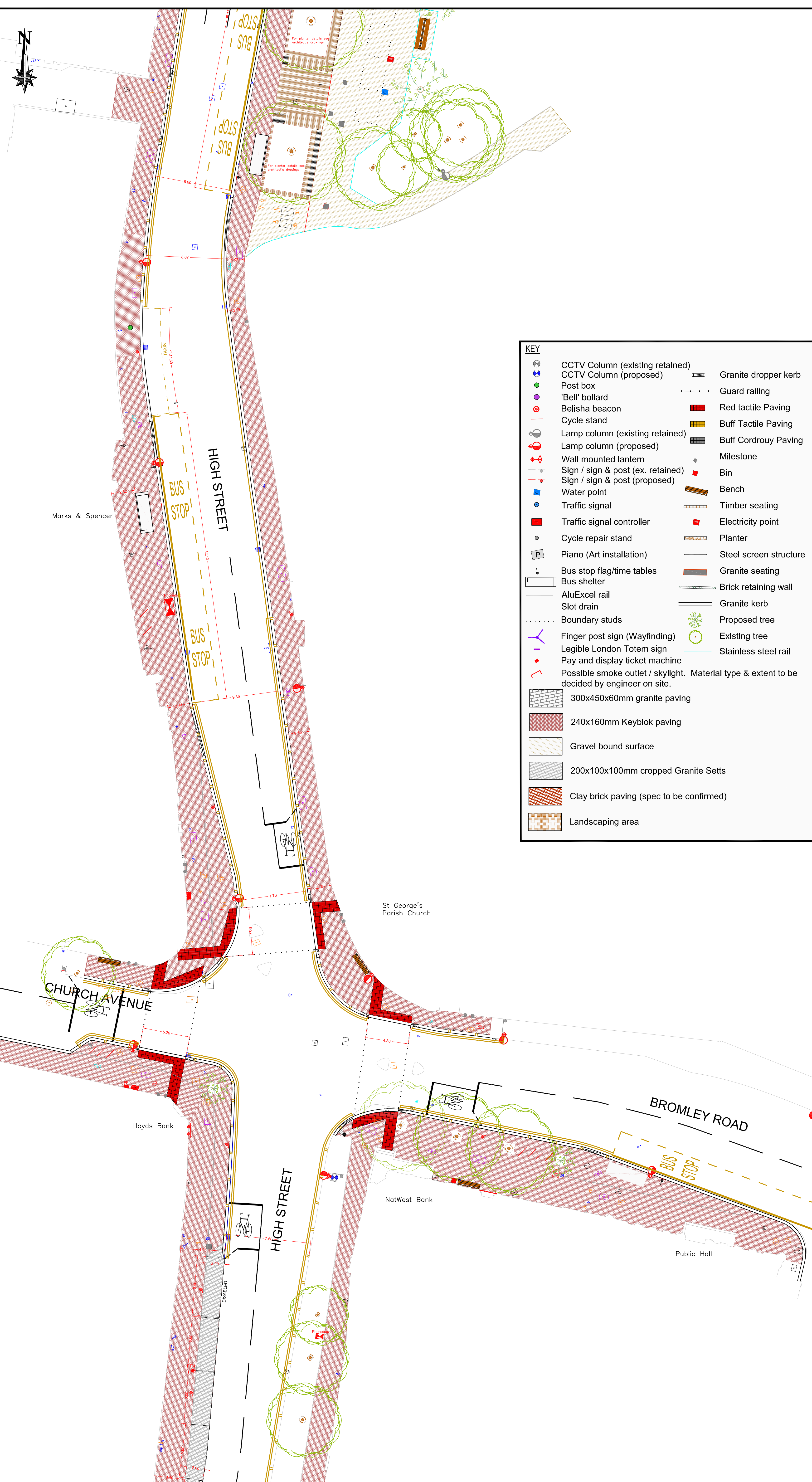

- Notes:**
- No information to be scaled from this drawing.
  - All road markings refer to the "Traffic Signs Regulations and General Directions 2016". Refer to drawing number BHS/RM/101.
  - This drawing is to be read in conjunction with all relevant drawings.
  - All levels and co-ordinates in Ordnance Survey Grid.
  - This drawing may not be used, modified, reproduced or relied upon by third parties, except as agreed or as required by law. Topocrew accepts no responsibility, and denies any liability whatsoever, to any party that uses or relies on this drawing without express written consent. Do not scale this document.

**KEY**

	CCTV Column (existing retained)		Granite dropper kerb
	CCTV Column (proposed)		Guard railing
	Post box		Red tactile Paving
	'Bell' bollard		Buff Tactile Paving
	Belisha beacon		Buff Cordrouy Paving
	Cycle stand		Milestone
	Lamp column (existing retained)		Bin
	Lamp column (proposed)		Bench
	Wall mounted lantern		Timber seating
	Sign / sign & post (ex. retained)		Electricity point
	Sign / sign & post (proposed)		Planter
	Water point		Steel screen structure
	Traffic signal		Granite seating
	Traffic signal controller		Brick retaining wall
	Cycle repair stand		Granite kerb
	Piano (Art installation)		Proposed tree
	Bus stop flag/time tables		Existing tree
	Bus shelter		Stainless steel rail
	AluExcel rail		
	Slot drain		
	Boundary studs		
	Finger post sign (Wayfinding)		
	Legible London Totem sign		
	Pay and display ticket machine		
	Possible smoke outlet / skylight. Material type & extent to be decided by engineer on site.		
	300x450x60mm granite paving		
	240x160mm Keyblok paving		
	Gravel bound surface		
	200x100x100mm cropped Granite Setts		
	Clay brick paving (spec to be confirmed)		
	Landscaping area		

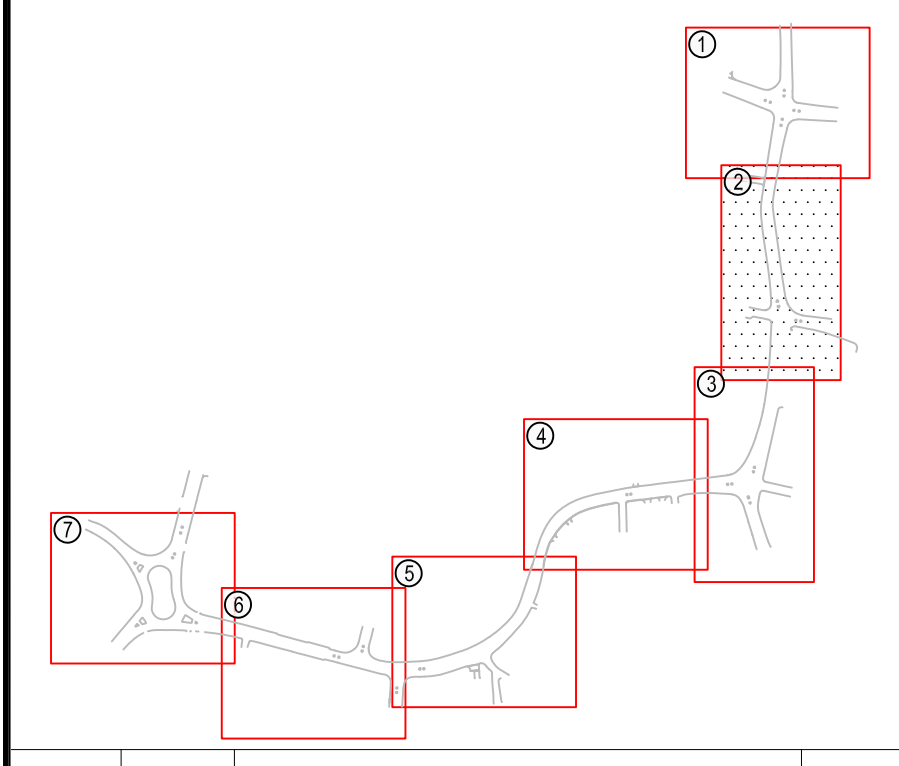

Rev No.	Date	Description	By
G	8 Dec	Various changes	GK
F	23 Nov	Various changes	GK
D	17 Oct	Various changes after second safety audit	GK
C	14 Sep	Various changes after safet audit	GK
B	27 June	First Issue	GK
A	25 May	Various revisions as a result of changes to the scheme	SR

**TITLE:**  
 Beckenham High Street  
 General Arrangement  
 GA 2 Beckenham Green to Bromley  
 Road Junction



Sheet: Sheet 2 of 7	Designed by: Various
Date: Dec 2016	Drawn by: SR
Scale & Drawing Size: 1:200 @ A1	Checked by: GK
Drawing No: BHS/700/GA	Revision: G



**KEY**

	CCTV Column (existing retained)		Granite dropper kerb
	CCTV Column (proposed)		Guard railing
	Post box		Red tactile Paving
	'Bell' bollard		Buff Tactile Paving
	Belisha beacon		Buff Cordrouy Paving
	Cycle stand		Milestone
	Lamp column (existing retained)		Bin
	Lamp column (proposed)		Bench
	Wall mounted lantern		Timber seating
	Sign / sign & post (ex. retained)		Electricity point
	Sign / sign & post (proposed)		Planter
	Water point		Steel screen structure
	Traffic signal		Granite seating
	Traffic signal controller		Brick retaining wall
	Cycle repair stand		Granite kerb
	Piano (Art installation)		Proposed tree
	Bus stop flag/time tables		Existing tree
	Bus shelter		Stainless steel rail
	AluExcel rail		
	Slot drain		
	Boundary studs		
	Finger post sign (Wayfinding)		
	Legible London Totem sign		
	Pay and display ticket machine		
	Possible smoke outlet / skylight. Material type & extent to be decided by engineer on site.		
	300x450x60mm granite paving		
	240x160mm Keyblok paving		
	Gravel bound surface		
	200x100x100mm cropped Granite Setts		
	Clay brick paving (spec to be confirmed)		
	Landscaping area		

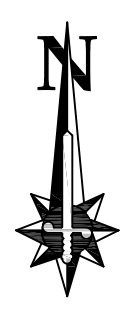

- Notes:**
1. No information to be scaled from this drawing.
  2. All road markings refer to the "Traffic Signs Regulations and General Directions 2016". Refer to drawing number BHS/RM/101.
  3. This drawing is to be read in conjunction with all relevant drawings.
  4. All levels and co-ordinates in Ordnance Survey Grid.
  5. This drawing may not be used, modified, reproduced or relied upon by third parties, except as agreed or as required by law. Topocrew accepts no responsibility, and denies any liability whatsoever, to any party that uses or relies on this drawing without express written consent. Do not scale this document.

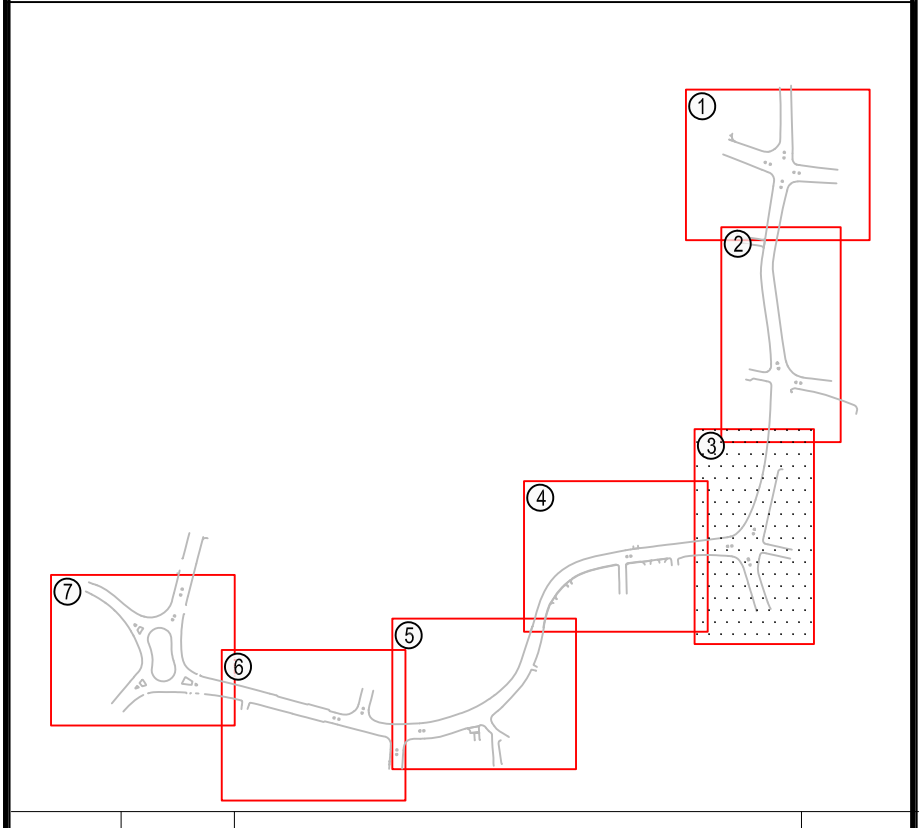

Rev No.	Date	Description	By
G	8 Dec	Various changes	GK
F	23 Nov	Various changes	GK
D	17 Oct	Various changes after second safety audit	GK
C	14 Sep	Various changes after safety audit	GK
B	27 June	First Issue	GK
A	25 May	Various revisions as a result of changes to the scheme	SR

TITLE:  
**Beckenham High Street  
 General Arrangement**  
 GA 3 Thorntons Corner -



Sheet: Sheet 3 of 7	Designed by: Various
Date: Dec 2016	Drawn by: SR
Scale & Drawing Size: 1:200 @ A1	Checked by: GK
Drawing No: BHS/700/GA	Revision: G



**KEY**

- CCTV Column (existing retained)
- CCTV Column (proposed)
- Post box
- 'Bell' bollard
- Belisha beacon
- Cycle stand
- Lamp column (existing retained)
- Lamp column (proposed)
- Wall mounted lantern
- Sign / sign & post (ex. retained)
- Sign / sign & post (proposed)
- Water point
- Traffic signal
- Traffic signal controller
- Cycle repair stand
- Piano (Art installation)
- Bus stop flag/time tables
- Bus shelter
- AluExcel rail
- Slot drain
- Boundary studs
- Finger post sign (Wayfinding)
- Legible London Totem sign
- Pay and display ticket machine
- Possible smoke outlet / skylight. Material type & extent to be decided by engineer on site.
- 300x450x60mm granite paving
- 240x160mm Keyblok paving
- Gravel bound surface
- 200x100x100mm cropped Granite Setts
- Clay brick paving (spec to be confirmed)
- Landscaping area
- Granite dropper kerb
- Guard railing
- Red tactile Paving
- Buff Tactile Paving
- Buff Cordrouy Paving
- Milestone
- Bin
- Bench
- Timber seating
- Electricity point
- Planter
- Steel screen structure
- Granite seating
- Brick retaining wall
- Granite kerb
- Proposed tree
- Existing tree
- Stainless steel rail

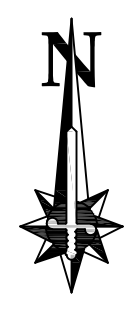

- Notes:**
1. No information to be scaled from this drawing.
  2. All road markings refer to the "Traffic Signs Regulations and General Directions 2016". Refer to drawing number BHS/RM/101.
  3. This drawing is to be read in conjunction with all relevant drawings.
  4. All levels and co-ordinates in Ordnance Survey Grid.
  5. This drawing may not be used, modified, reproduced or relied upon by third parties, except as agreed or as required by law. Topocrew accepts no responsibility, and denies any liability whatsoever, to any party that uses or relies on this drawing without express written consent. Do not scale this document.
  6. Paving orientation is only indicative. For exact paving orientation refer to East's drawing 102-BPR-SK-016-Proposed paving orientation.

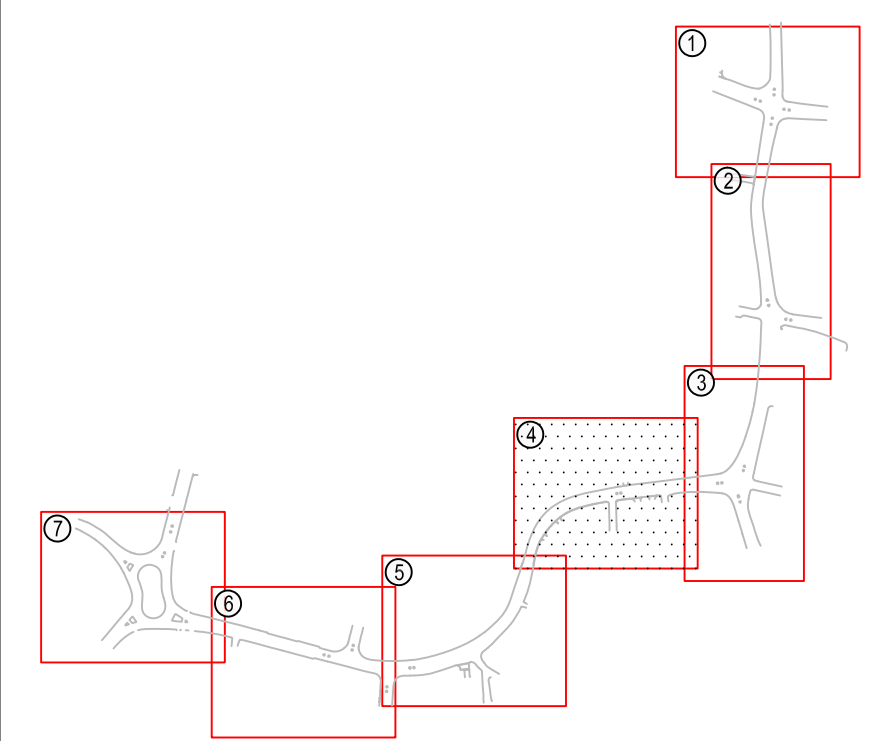

Rev No.	Date	Description	By
G	8 Dec	Various changes	GK
F	23 Nov	Various changes	GK
D	17 Oct	Various changes after second safety audit	GK
C	14 Sep	Various changes after safety audit	GK
B	27 June	First Issue	GK
A	25 May	Various revisions at a result of changes to the scheme	SR

**Beckenham High Street**  
**General Arrangement**  
 GA 4 Thorntons Corner to S Georges pub



Sheet:	Sheet 4 of 7	Designed by:	Various
Date:	Dec 2016	Drawn by:	SR
Scale & Drawing Size:	1:200 @ A1	Checked by:	GK
Drawing No:	BHS/700/GA	Revision:	G

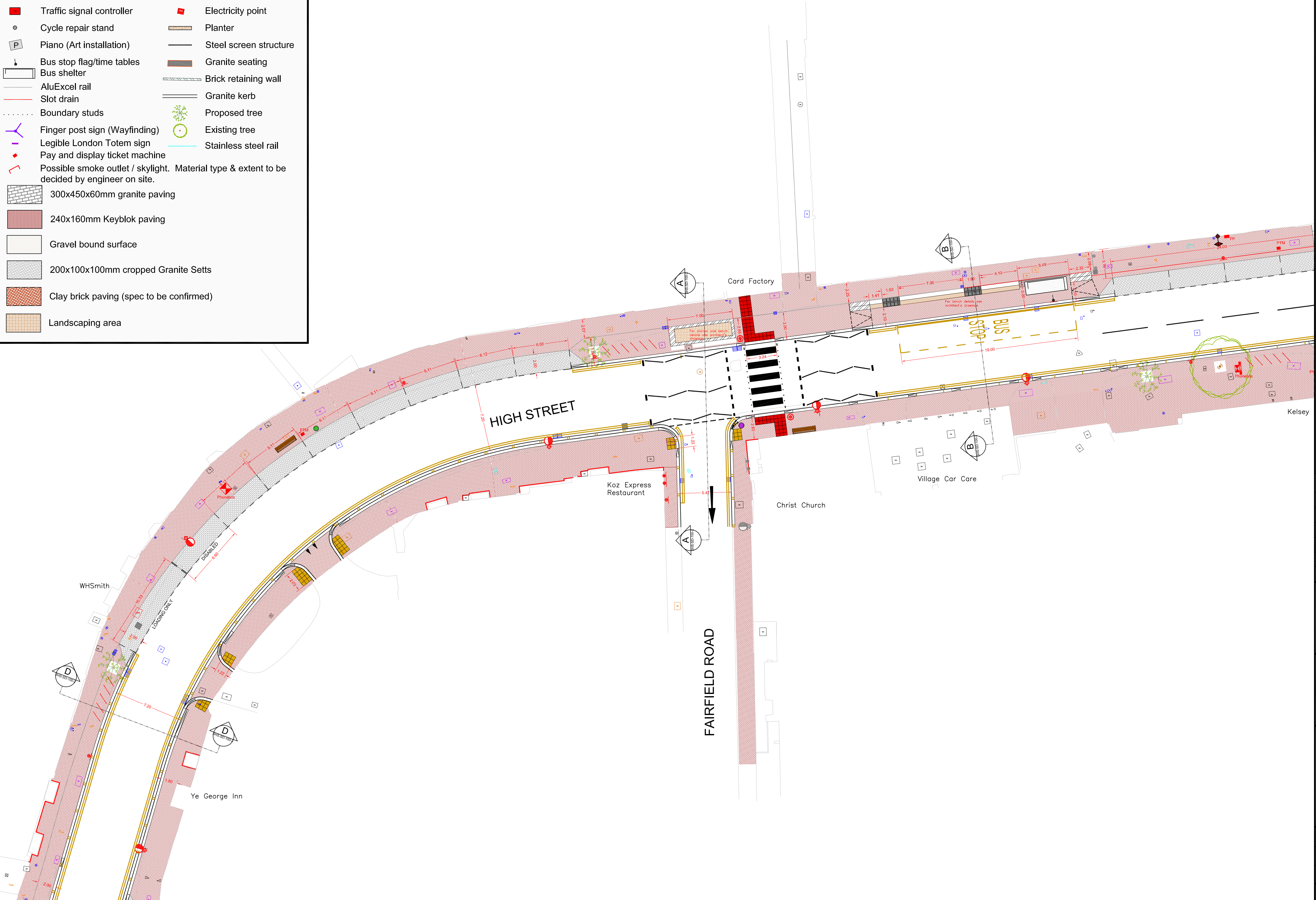



**KEY**

	CCTV Column (existing retained)		Granite dropper kerb
	CCTV Column (proposed)		Guard railing
	Post box		Red tactile Paving
	'Bell' bollard		Buff Tactile Paving
	Belisha beacon		Buff Cordrouy Paving
	Cycle stand		Milestone
	Lamp column (existing retained)		Bin
	Lamp column (proposed)		Bench
	Wall mounted lantern		Timber seating
	Sign / sign & post (ex. retained)		Electricity point
	Sign / sign & post (proposed)		Planter
	Water point		Steel screen structure
	Traffic signal		Granite seating
	Traffic signal controller		Brick retaining wall
	Cycle repair stand		Granite kerb
	Piano (Art installation)		Proposed tree
	Bus stop flag/time tables		Existing tree
	Bus shelter		Stainless steel rail
	AluExcel rail		
	Slot drain		
	Boundary studs		
	Finger post sign (Wayfinding)		
	Legible London Totem sign		
	Pay and display ticket machine		
	Possible smoke outlet / skylight. Material type & extent to be decided by engineer on site.		

	300x450x60mm granite paving
	240x160mm Keyblok paving
	Gravel bound surface
	200x100x100mm cropped Granite Setts
	Clay brick paving (spec to be confirmed)
	Landscaping area

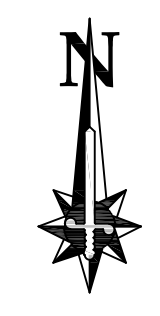
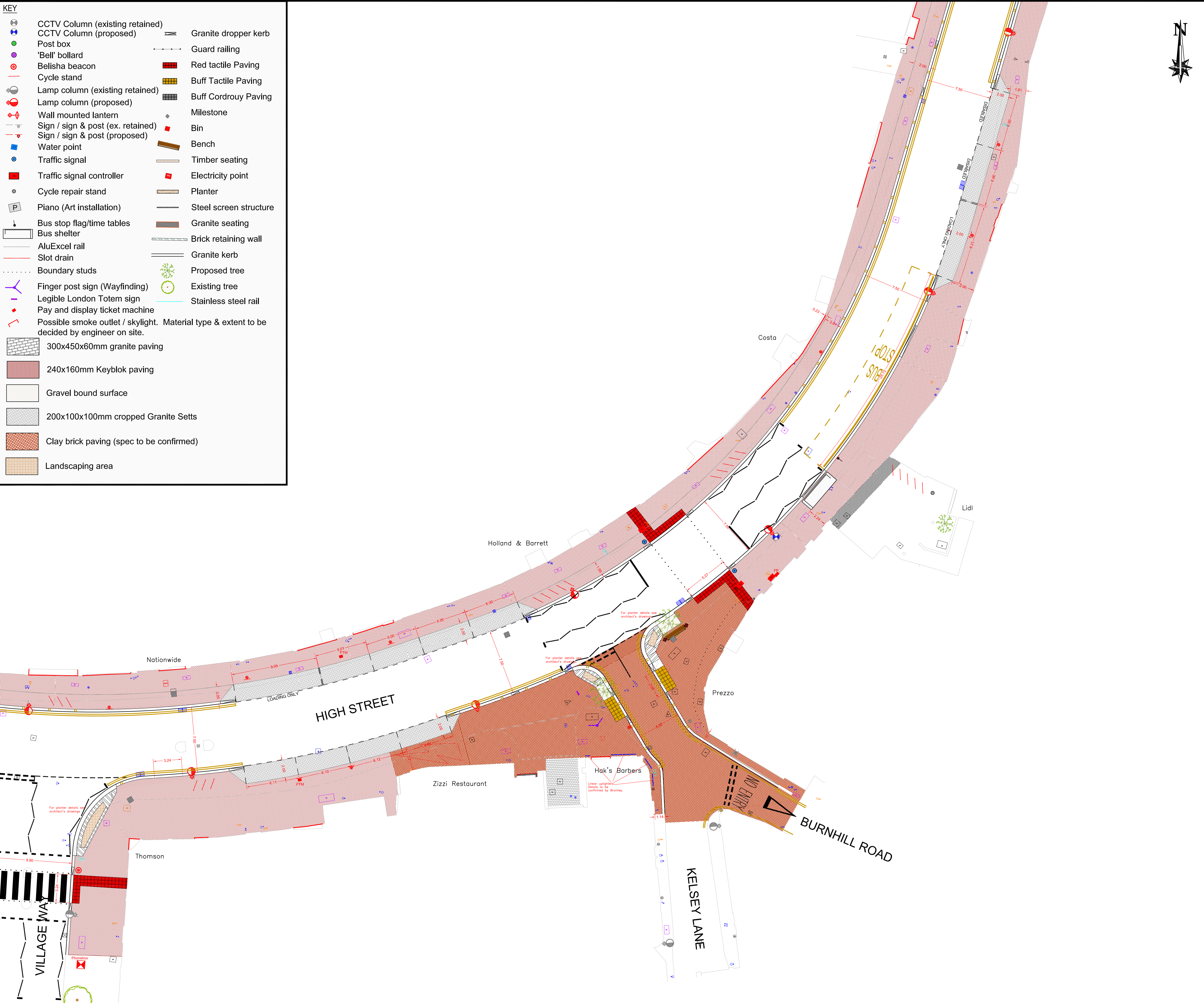

- Notes:**
- No information to be scaled from this drawing.
  - All road markings refer to the "Traffic Signs Regulations and General Directions 2016". Refer to drawing number BHS/RM/101.
  - This drawing is to be read in conjunction with all relevant drawings.
  - All levels and co-ordinates in Ordnance Survey Grid.
  - This drawing may not be used, modified, reproduced or relied upon by third parties, except as agreed or as required by law. Topocrew accepts no responsibility, and denies any liability whatsoever, to any party that uses or relies on this drawing without express written consent. Do not scale this document.
  - Paving orientation is only indicative. For exact paving orientation refer to East's drawing 102-BPR-SK-016-Proposed paving orientation.

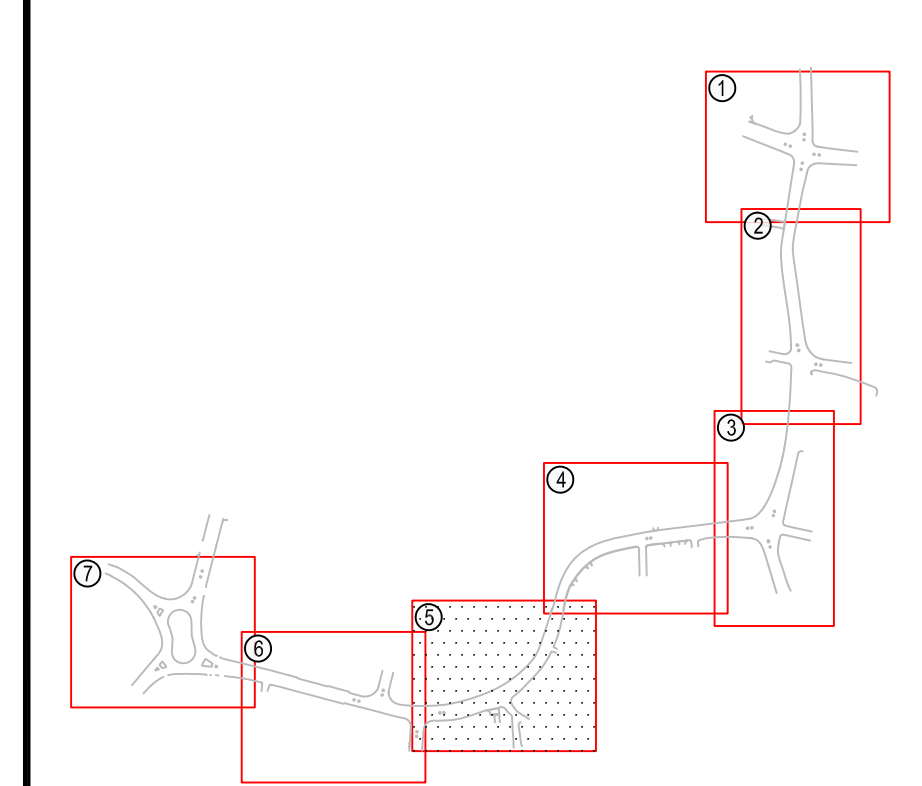

Rev No.	Date	Description	By
G	8 Dec	Various changes	GK
F	23 Nov	Various changes	GK
D	17 Oct	Various changes after safety audit	GK
C	14 Sep	Various changes after safety audit	GK
B	27 June	First Issue	GK
A	25 May	Various revisions at a result of changes to the scheme	SR

TITLE:  
**Beckenham High Street**  
**General Arrangement**  
 GA 5 St Georges pub to Village Way -



Sheet: Sheet 5 of 7	Designed by: Various
Date: Dec 2016	Drawn by: SR
Scale & Drawing Size: 1:200 @ A1	Checked by: GK
Drawing No: BHS/700/GA	Revision: G



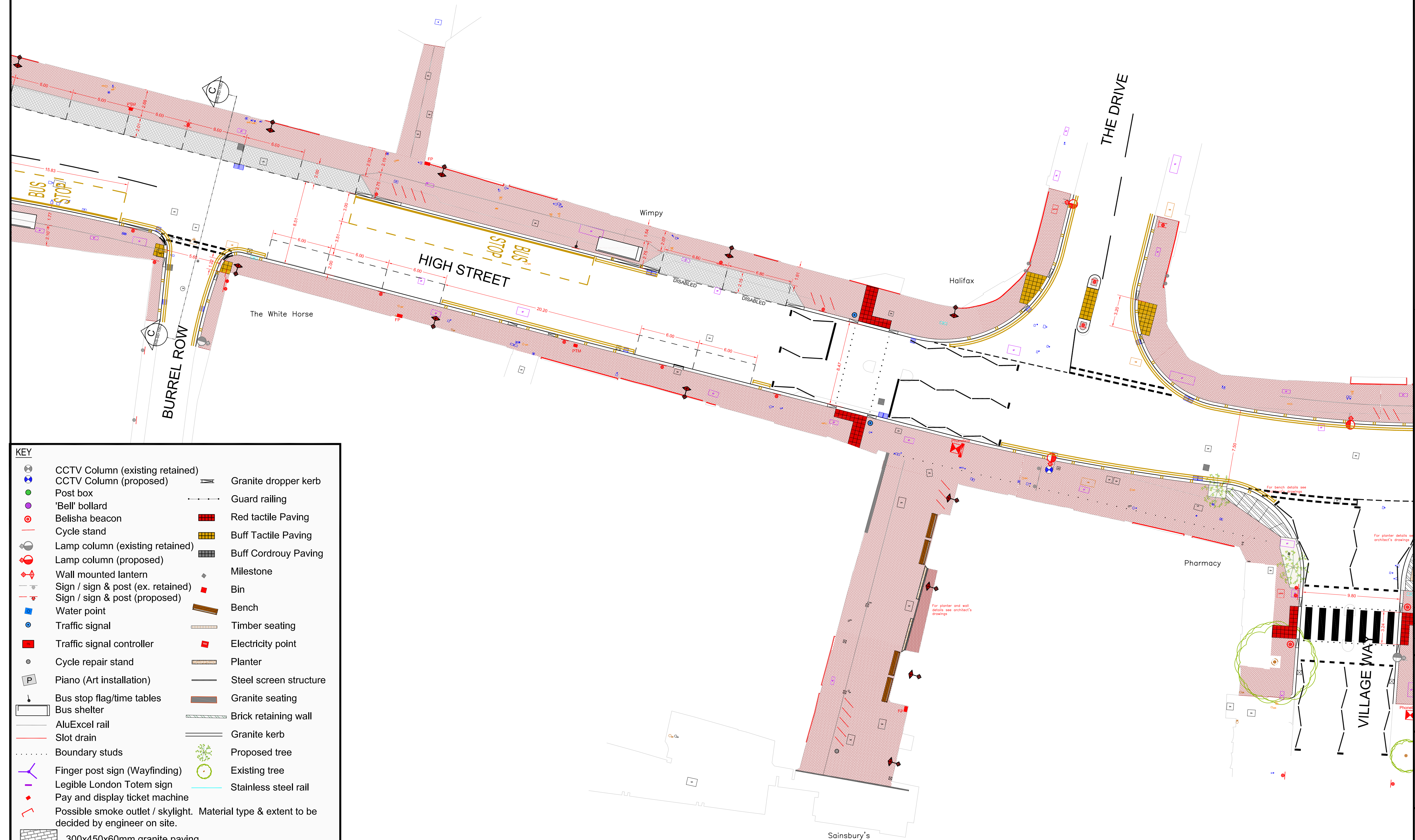
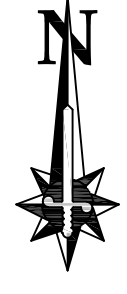

- Notes:
- No information to be scaled from this drawing.
  - All road markings refer to the "Traffic Signs Regulations and General Directions 2016". Refer to drawing number BHS/RM/101.
  - This drawing is to be read in conjunction with all relevant drawings.
  - All levels and co-ordinates in Ordnance Survey Grid.
  - This drawing may not be used, modified, reproduced or relied upon by third parties, except as agreed or as required by law. Topocrew accepts no responsibility, and denies any liability whatsoever, to any party that uses or relies on this drawing without express written consent. Do not scale this document.
  - Paving orientation is only indicative. For exact paving orientation refer to East's drawing 102-BPR-SK-016-Proposed paving orientation.

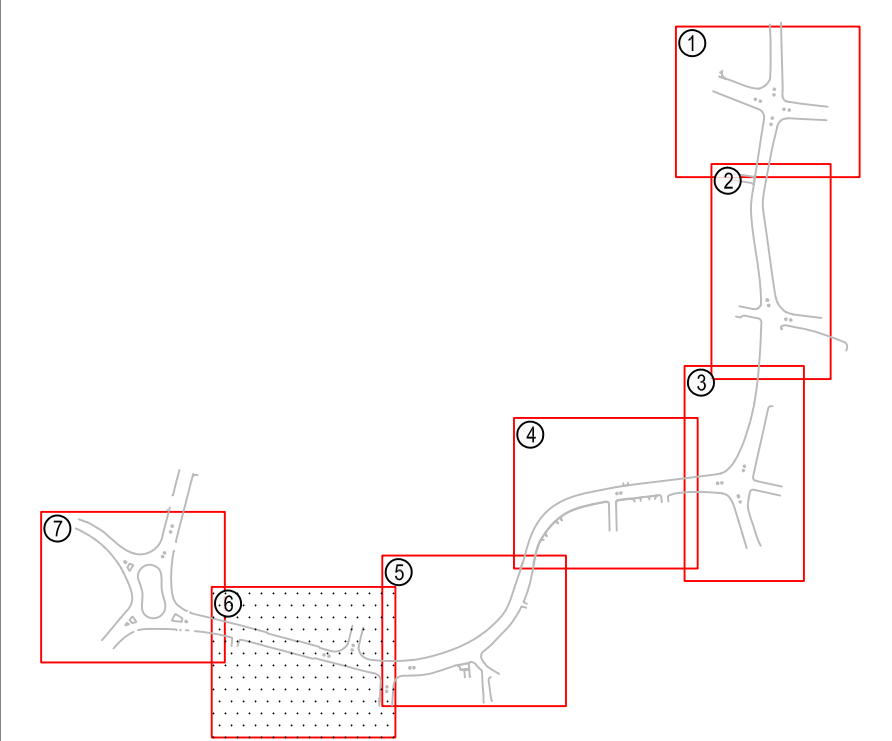

**KEY**

	CCTV Column (existing retained)		Granite dropper kerb
	CCTV Column (proposed)		Guard railing
	Post box		Red tactile Paving
	'Bell' bollard		Buff Tactile Paving
	Belisha beacon		Buff Cordrouy Paving
	Cycle stand		Milestone
	Lamp column (existing retained)		Bin
	Lamp column (proposed)		Bench
	Wall mounted lantern		Timber seating
	Sign / sign & post (ex. retained)		Electricity point
	Sign / sign & post (proposed)		Planter
	Water point		Steel screen structure
	Traffic signal		Granite seating
	Traffic signal controller		Brick retaining wall
	Cycle repair stand		Granite kerb
	Piano (Art installation)		Proposed tree
	Bus stop flag/time tables		Existing tree
	Bus shelter		Stainless steel rail
	AluExcel rail		
	Slot drain		
	Boundary studs		
	Finger post sign (Wayfinding)		
	Legible London Totem sign		
	Pay and display ticket machine		
	Possible smoke outlet / skylight. Material type & extent to be decided by engineer on site.		
	300x450x60mm granite paving		
	240x160mm Keyblok paving		
	Gravel bound surface		
	200x100x100mm cropped Granite Setts		
	Clay brick paving (spec to be confirmed)		
	Landscaping area		

Rev No.	Date	Description	By
G	8 Dec	Various changes	GK
F	23 Nov	Various changes	GK
D	17 Oct	Various changes after second safety audit	GK
C	14 Sep	Various changes after safety audit	GK
B	27 June	First Issue	GK
A	25 May	Various revisions at a result of changes to the scheme	SR

TITLE:  
**Beckenham High Street**  
**General Arrangement**  
**GA 61 Village way to Burrell Row -**



Sheet:	Sheet 6 of 7	Designed by:	Various
Date:	Dec 2016	Drawn by:	SR
Scale & Drawing Size:	1:200 @ A1	Checked by:	GK
Drawing No:	BHS/700/GA		Revision:
			G



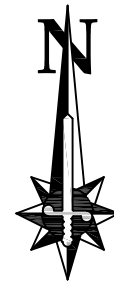

BECKENHAM ROAD

RECTORY ROAD

Post Office

Odeon

Bricklayers Arms

HIGH STREET

CROYDON ROAD

- Notes:
- No information to be scaled from this drawing.
  - All road markings refer to the "Traffic Signs Regulations and General Directions 2016". Refer to drawing number BHS/RM/101.
  - This drawing is to be read in conjunction with all relevant drawings.
  - All levels and co-ordinates in Ordnance Survey Grid.
  - This drawing may not be used, modified, reproduced or relied upon by third parties, except as agreed or as required by law. Topocrew accepts no responsibility, and denies any liability whatsoever, to any party that uses or relies on this drawing without express written consent. Do not scale this document.
  - Paving orientation is only indicative. For exact paving orientation refer to East's drawing 102-BPR-SK-016-Proposed paving orientation.

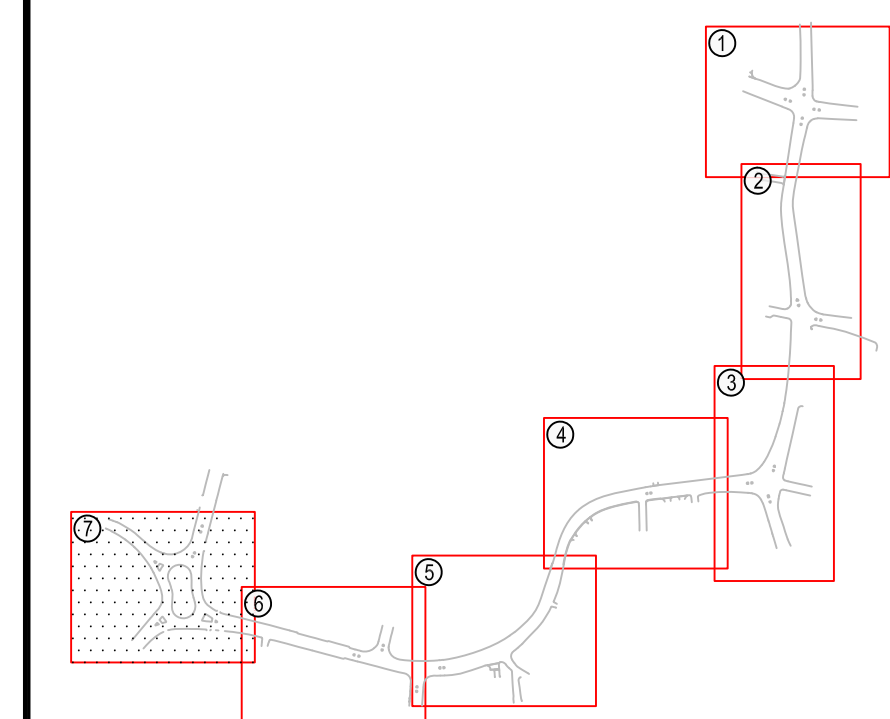

Rev No.	Date	Description	By
G	8 Dec	Various changes	GK
F	23 Nov	Various changes	GK
D	17 Oct	Various changes after second safety audit	GK
C	14 Sep	Various changes after safety audit	GK
B	27 June	First Issue	GK
A	25 May	Various revisions at a result of changes to the scheme	SR

TITLE:  
**Beckenham High Street**  
**General Arrangement**  
**GA 7 Burrell Row to War Memorial**  
**Roundabout**



Sheet:	Sheet 7 of 7	Designed by:	Various
Date:	Dec 2016	Drawn by:	SR
Scale & Drawing Size:	1:200 @ A1	Checked by:	GK
Drawing No:	BHS/700/GA	Revision:	G

KEY

	CCTV Column (existing retained)		Granite dropper kerb
	CCTV Column (proposed)		Guard railing
	Post box		Red tactile Paving
	'Bell' bollard		Buff Tactile Paving
	Belisha beacon		Buff Cordrouy Paving
	Cycle stand		Milestone
	Lamp column (existing retained)		Bin
	Lamp column (proposed)		Bench
	Wall mounted lantern		Timber seating
	Sign / sign & post (ex. retained)		Electricity point
	Sign / sign & post (proposed)		Planter
	Water point		Steel screen structure
	Traffic signal		Granite seating
	Traffic signal controller		Brick retaining wall
	Cycle repair stand		Granite kerb
	Piano (Art installation)		Proposed tree
	Bus stop flag/time tables		Existing tree
	Bus shelter		Stainless steel rail
	AluExcel rail		Possible smoke outlet / skylight. Material type & extent to be decided by engineer on site.
	Slot drain		300x450x60mm granite paving
	Boundary studs		240x160mm Keyblok paving
	Finger post sign (Wayfinding)		Gravel bound surface
	Legible London Totem sign		200x100x100mm cropped Granite Setts
	Pay and display ticket machine		Clay brick paving (spec to be confirmed)
	Possible smoke outlet / skylight. Material type & extent to be decided by engineer on site.		Landscaping area

